

RESPIRO R9 profi

THE BELT RAKE OF THE FUTURE



REITER
www.reiter-respiro.com

The future of raking: **RESPIRO**



DI Thomas Reiter, Founder and Managing Director

Cleanest forage due to flexible belt rake

By using the belt rake with trailing tines and flexible pick-up, a new era in animal health & forage productivity begins. In addition, harvesting costs are reduced, there is less damage to harvesting machinery as stones are left on the ground, and the ash content also drops enormously. These and many other factors help to ensure that the full yield of the forage is utilised.

www.reiter-respiro.com

THE PICK-UP REVOLUTION: BEST SOIL ADAPTATION

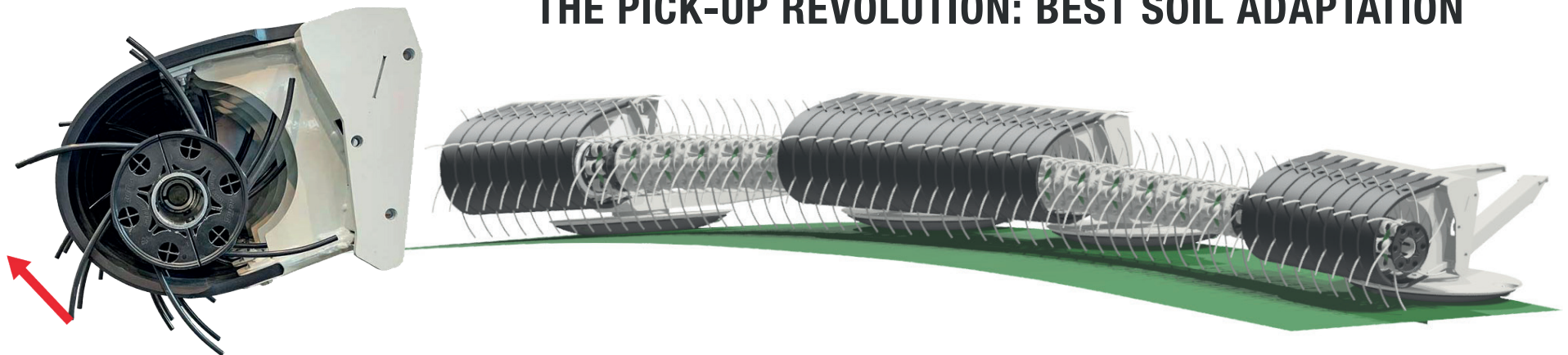



QUALITY. PROFIT. JOY.

**PICK-UP WITH
DRAGGING TINES,
SMALL PICK-UP DIAMETER
& FLEXIBLE PICK-UP**

Table of contents

The future of raking	... 2
Sweeping versus lifting	... 4
Added value farmer and contractor	... 6
Increase in forage productivity	... 8

Added value & versatility	... 10
Flexible pick-up	... 12
Sliding disc close to the tine	... 13
Trailing tine	... 14
Anti-Loss System	... 15
Camless pick-up	... 16
Small diameter	... 17
Conveyor rotor & swath roller	... 18

Detailed view RESPIRO R9 profi	... 20
Possibilities for swath placement	... 22
Robust & manoeuvrable	... 24
Hydraulic drive & road transport	... 25
4-wheel chassis	... 26
Lifting on headland & straw application	... 27
4-link kinematics	... 28
Spring suspension	... 29
Operation	... 30
Data sheet & tractor requirements	... 31

Cleanest forage

The technology

RESPIRO R9 in detail

Is sweeping with the rotary rake still up to date?

How much longer are we going to go without extracting the full value of the basic fodder?

The lines in the picture illustrate the enormous succession of tines when swathing and the long path when sweeping the crop on the ground.

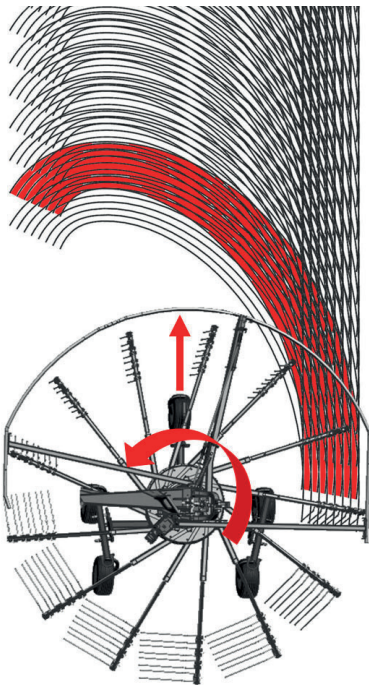

Rotary rake: In practice, frequent and aggressive ground contact is unavoidable: Dirt and foreign matter ingress with all the known disadvantages.

Inevitable consequences due to contaminated feed!

Deficits in performance

- ▶ Compacted / knotted swath
- ▶ Limited working speed
- ▶ Poorer post-drying on the swath
- ▶ Inflexible in working width and depositing direction

Animal health risks

- ▶ Contaminated feed causes inflammation, fertility and hoof problems
- ▶ Less performance
- ▶ Colics in horses

Contaminations

- ▶ Dust, soil, sand
- ▶ Stones and foreign objects
- ▶ Unhelpful bacteria and fungi
- ▶ Slurry / manure residues
- ▶ Mice
- ▶ Rotten undergrass

Losses

- ▶ Leaf loss
- ▶ Crumbling losses
- ▶ Rake losses
- ▶ Losses at the feeding fence
- ▶ Wear on machinery

Lifting instead of sweeping.
THAT'S THE NEW WAY.

Cleanest forage



RESPIRO exploits the full potential

If you make cleanest forage your top priority, you have to move from sweeping to lifting.

Clean forage

Noticeable reduction of all kinds of contamination = best forage quality

Animal Health

Better feed keeps animals healthy, less worry, more success

High performance + flexibility

Loose swath, no twisting, high working speed, full flexibility in working width, left and right delivery possible

Lowest losses

Less leaf loss improve protein content, very little wear

For all uses

Ideally suitable for difficult working conditions

RESPIRO technology creates advantages that

Added value for the farmer

Less forage contamination

- ▶ Less ash content, more energy, more protein → Higher milk yield
 - ▶ Better fermentation quality, tastier → higher feed intake
- ▶ Best feed quality ensures animal health → less veterinary costs
 - ▶ Higher herd age

Reduced losses

- ▶ Less leaf loss, more crude protein → ideal for legumes
- ▶ Less crumble loss delivers more output from the basic feed
 - ▶ More crop yield per ha due to fewer raking losses
 - ▶ No lying rotting grass

Swath loose, even, perfectly sized

- ▶ Looser placement, better drying - earlier start of raking possible
- ▶ Uniform swath for high performance of the following machine

More benefits

- ▶ Flexible cleaning out of corners and pointed fields by loading the stopped belt
 - ▶ Protection of the sward
- ▶ Less wear due to few stones and foreign objects in the forage
 - ▶ No broken tines in the forage
- ▶ Higher lifetime performance of the machines
 - ▶ Lower repair costs



Reitner M. , farmer from Laussa, AT

RESPIRO customer since 2019 (RESPIRO R9 profi)

” We hardly find any soil in the cutting system of our loader wagon - that convinced us! We were able to reduce the ash content by 25 g/kg DM on average. Performance and suitability for slopes are excellent!

”



our customers will never want to do without.

Reuter H. , contractor from Niedersachsen, DE
RESPIRO customer since 2019 (2x RESPIRO R9 profi)



”Our customers appreciate the very good raking quality of the pick-up & the higher milk yield due to less dirt in the forage. We have noticeably less wear and tear and better utilisation of the forage harvester.”

Added value for the contractor

Less wear

- ▶ Lower wear costs on the rake due to passive tines
- ▶ Few tine breaks, tines cannot get lost
- ▶ Fewer stones and foreign objects - less wear and tear - less knife grinding in the cutterbars of the following harvesting machines
- ▶ Higher lifetime performance of the machines

Versatile use: utilisation of rake and following chain

- ▶ In all fields of application grassland, forage, lucerne, straw swath turning, maize straw, from long horse hay to the short last cut in permanent grassland
- ▶ Flexibility through centre or side swath placement with a lot or little harvest mass, always the right swath size and mass for efficient utilisation of the following harvest chain
- ▶ Repeated overlifting does not result in swath tapping and losses
- ▶ High working speed for high area output and performance without loss of quality
- ▶ Fuel savings for the entire harvest chain

Less forage contamination

- ▶ Image gain at the customer due to clean forage and thus higher basic forage productivity
- ▶ Higher income per hour or hectare
- ▶ Fewer failures due to foreign objects in the self-propelled forage harvester, loader wagon or baler



CLEAN. ENERGY-RICH. VALUABLE.



Increase in forage productivity

HEALTH . FERTILITY . LIFE PERFORMANCE .

The goal: reduction of crude ash content

With the **RESPIRO**, thanks to the flexible pick-up and the trailing tines, a reduction of the crude ash content by up to 40 g/kg DM is possible. Clean forage is the basis for increasing forage productivity. The more difficult the harvesting conditions, the greater the potential for productivity increase through the use of **RESPIRO** technology.

Rule of thumb: Milk production

- ▶ The reduction of 10 g raw ash/kg DM in the feed increases on average...
 - ▶ ...the energy concentration (NEL) by about 0.1 MJ/kg DM
 - ▶ ...the crude protein content (XP) by 1.6 g/kg DM
- ▶ Energy requirement of the cow for milk production: 3.17 MJ NEL/kg milk

Ruben D. , farmer from Niedersachsen, DE

RESPIRO customer since 2019



“ The veterinary costs of our 108 cow herd have decreased by 50 € / cow & year. Milk yield has increased by more than 10 % from 9,600 kg to 10,600 kg / cow & year! ”

Enormous potential: Reduction of crude ash content with the **RESPIRO** technology

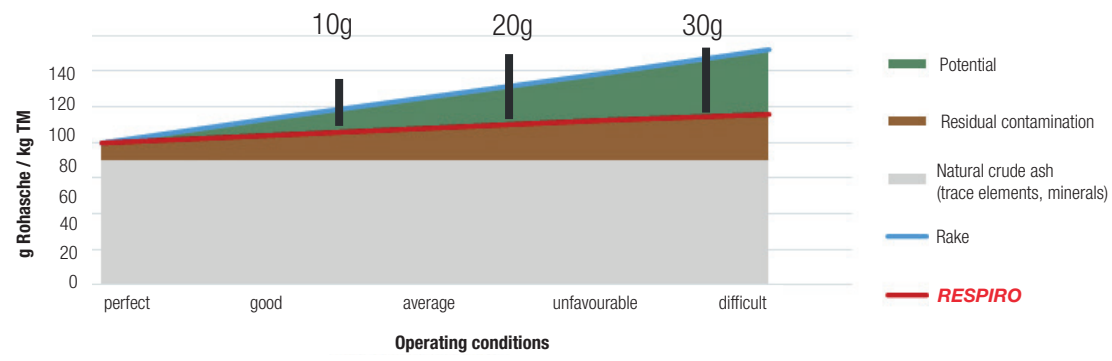

1 Higher feed value

Dirt displaces valuable energy and protein in the feed. If you reduce the amount of dirt, the cow automatically takes in more energy and protein when eating, **thus increasing the amount of milk.**

EXAMPLE

Additional yield per cow*

- 0,5 kg milk / day
- 150 kg milk / year
- 60 € / cow & year

Savings of 15 kg soy / cow & year = 6 € / cow & year
Each cow eats 60 kg less dirt & year !!!!!

2 Increase feed intake

Clean fodder is tastier, the cows are more energetic due to less dirt in the fodder and this increases their appetite. The daily feed intake increases and so does the amount of milk.

▶ 0.33 kg DM / day higher basic feed intake

EXAMPLE

Additional yield per cow*

- 0,63 kg milk / day
- 188 kg milk / year
- 75 € / cow & year

INTERIM STATEMENT

PROFIT POTENTIAL*

Higher feed value: 60 € / cow & year
+ Soy saving: 6 € / cow & year
+ feed intake 75 € / cow & year

141 € / cow & year



3 Other profitable factors

- ▶ Lower veterinary costs
- ▶ Fewer worries in the barn
- ▶ Higher vitality, higher herd age
- ▶ Lower field losses
- ▶ Better ensiling, less fermentation losses
- ▶ Savings on silage additives
- ▶ Less feed loss at the feed table
- ▶ and much more...



EXAMPLE

Calculation 100 cow farm

- 14,100 € additional income / year

- 6 tonnes less dirt in the feed

Jason C. , Fiber & Fresh from New Zealand

RESPIRO customer since 2020 (R9 profi)

It's worth getting started. At any time.

Invest in the right technology now

” *Our RESPIRO performs over 8,000 ha per year. We are very satisfied with the way the machine works. The expenditure for wear and maintenance is low. The wear costs of our forage harvester have dropped dramatically.* ”
The technology has completely convinced us.



Reduction of costs of the self propelled harvester

- ▶ Uniform loose swath
 - ▶ Chopping speed can be increased - up to 30% more output on the same swath
- ▶ Put a larger working width in a swath
 - ▶ Better utilisation of the self propelled harvester (up to minus 50 % of the chopping time)
 - ▶ Lower diesel consumption
- ▶ Fewer passes of the harvesting chain
 - ▶ Less soil compaction



Increasing the area output during swathing

- ▶ Driving speeds of up to 25 km/h depending on field conditions with clean, loss-free forage collection
- ▶ Quick lifting and exact lowering of the work unit saves time
- ▶ Quick turning on the headland



Wear reduction of the harvesting technology

- ▶ Flexible pick-up & trailing tines leave stones & dirt on the ground
- ▶ Grind knives less often
- ▶ Wear reduction up to 50%
- ▶ Save fuel
- ▶ Reduced risk of damage from foreign objects
- ▶ Reliability of operation

Less crumb loss - more protein in the feed



Increase in crude protein content by 1% point

Versatility

RESPIRO technology is ideally suited for all applications: Grassland, forage, lucerne, straw, maize straw, from long horse hay to short last cut in permanent grassland

EXAMPLE

Additional yield per hectare*

- ➔ 100 kg more crude protein / ha & year
- ➔ 80 € additional yield / ha & year

Especially for sensitive forage crops with a high leaf content (clover, lucerne), the **RESPIRO** technology is better suited than conventional systems on the market.

The key factors are:

- ▶ Forage plants are lifted up very gently on the spot and not swept over the whole area
- ▶ Small pick-up diameter - low barrier, the crop mass is lifted gently
- ▶ Low tine impact speed - protection already starts with the lifting
- ▶ Material is transported onto the belt by the rotor: gentle on fodder compared to belt rakes with a large pick-up diameter, where the throwing energy is generated by the high tine speed.



The technology

*Example according to the following assumptions:

▶ Lucerne yield 10 t DM / ha and year

▶ HP soy (48% XP): 0.40 €/kg

Unique

The flexible pick-up from Reiter

The flexible pick-up is the heart of the **RESPIRO** belt rake. With pick-up widths of 3 m and more, the pick-up must be flexible so that the ground adaptation works.

This is the only way to achieve perfect work result in grassland. This unique position points the way to the future of belt rakes.

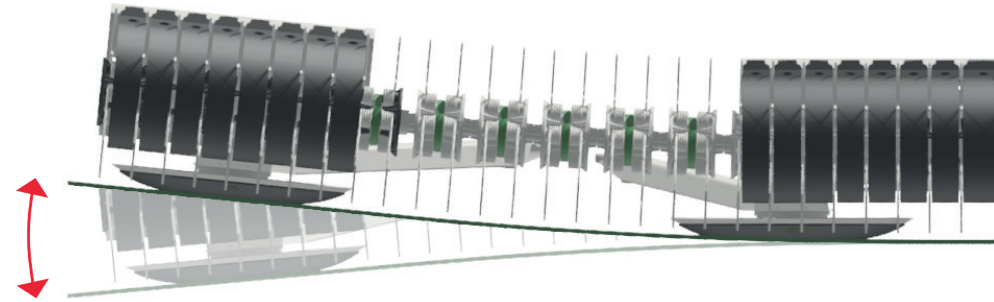

Due to the unique flexible pick-up in the **RESPIRO, we achieve unprecedented ground hugging. Even forage from deepenings is picked up cleanly and without loss.**

Best raking quality

Even under difficult working conditions, raking losses are low. This not only increases the overall yield but also the forage quality of the subsequent cuts.

Top quality - hectare by hectare, cut by cut.

No aggressive ground contact

Due to the flexibility of the pick-up, no aggressive ground contact is possible. This not only creates a good feeling in operation. It is the basis for top forage quality. The sward is also protected, which promotes re-growth.

Little wear on the tines

The pick-up tines only touch the ground sporadically. This minimises wear on the tines. That's what every practitioner wants.

Few broken tines

The trailing pick-up tines very rarely touch the ground. The logical consequence is maximum tine life.

In detail

The pick-up is divided into several segments - the two middle sliding discs guide the pick-up inside and support the belt body - the two outer sliding discs only guide the outer pick-up segments in height.

The elastic spine attached behind the Pick-Up connects the five-part structure of the yokes and keeps the Pick-Up in shape - this enables perfect ground hugging.

Elastic spine
PATENTED

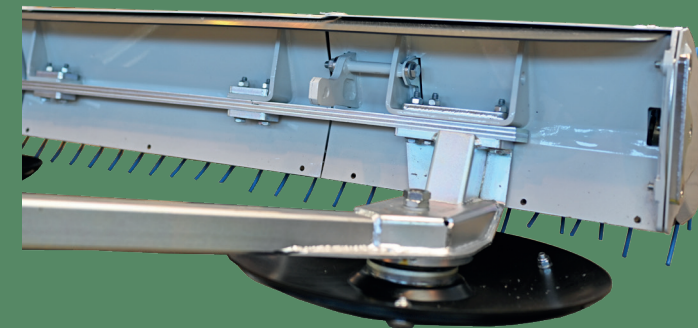

Best ground guide

Sliding discs close to the tine

The sliding discs are positioned as close as possible to the tine rake line. They guide the pick-up perfectly over the ground without leaving marks. Punching into the soil is virtually impossible. That is why the **RESPIRO** belt rake has no fixed skirts.

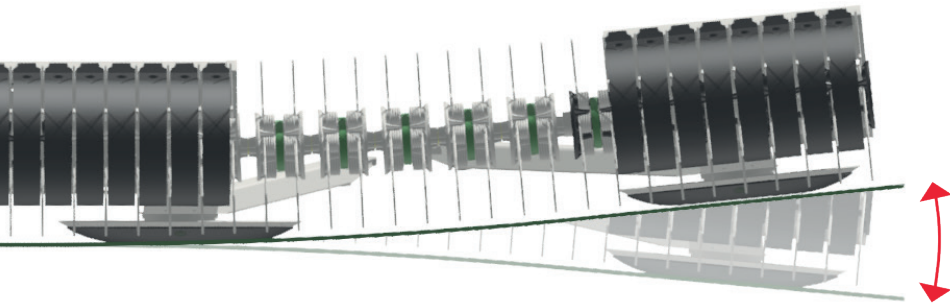

Free rotating

Protection of the turf and soil, even wear over the entire area and easy glide trough of foreign objects, soil and stones to the left or right of the sliding disc, as it is almost constantly in rotation.

Large contact surface

The large contact surface has a damping effect and thus reduces system oscillations and vibrations. Holes in the ground do not cause the pick-up to sag and thus ensure an ideal working result.

Simple wear part

The base plate carries the wear plate. The wear plate, made of hardened boron steel, is simple and cost-effective. This ensures that wear costs remain low even in difficult, hard ground conditions.



Via the truss, the forces are transmitted into the back

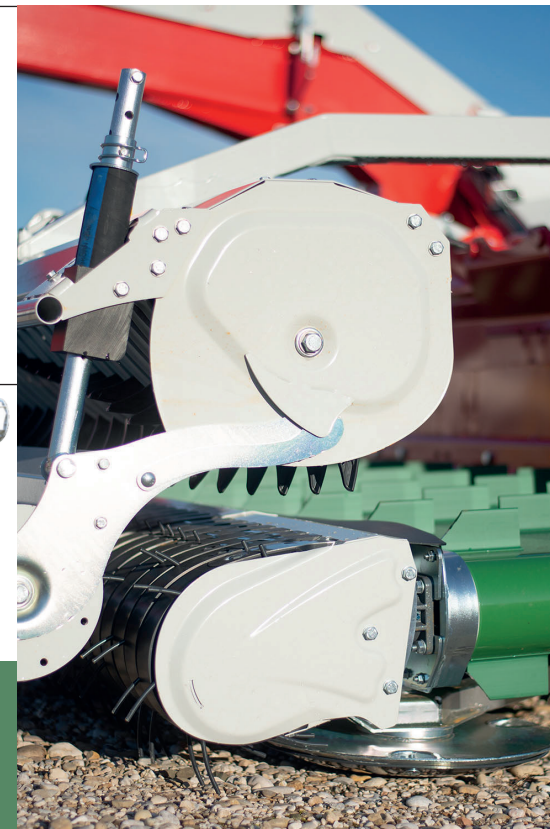

Leave stones

Trailing tines

Next to the flexible pick-up, the trailing tines are the most important component for the cleanest forage. The tines are arranged dragging on the rake line, which means they react passively when they come into contact with the ground. Forage is picked up cleanly, dirt, soil, stones and foreign objects remain on the ground.

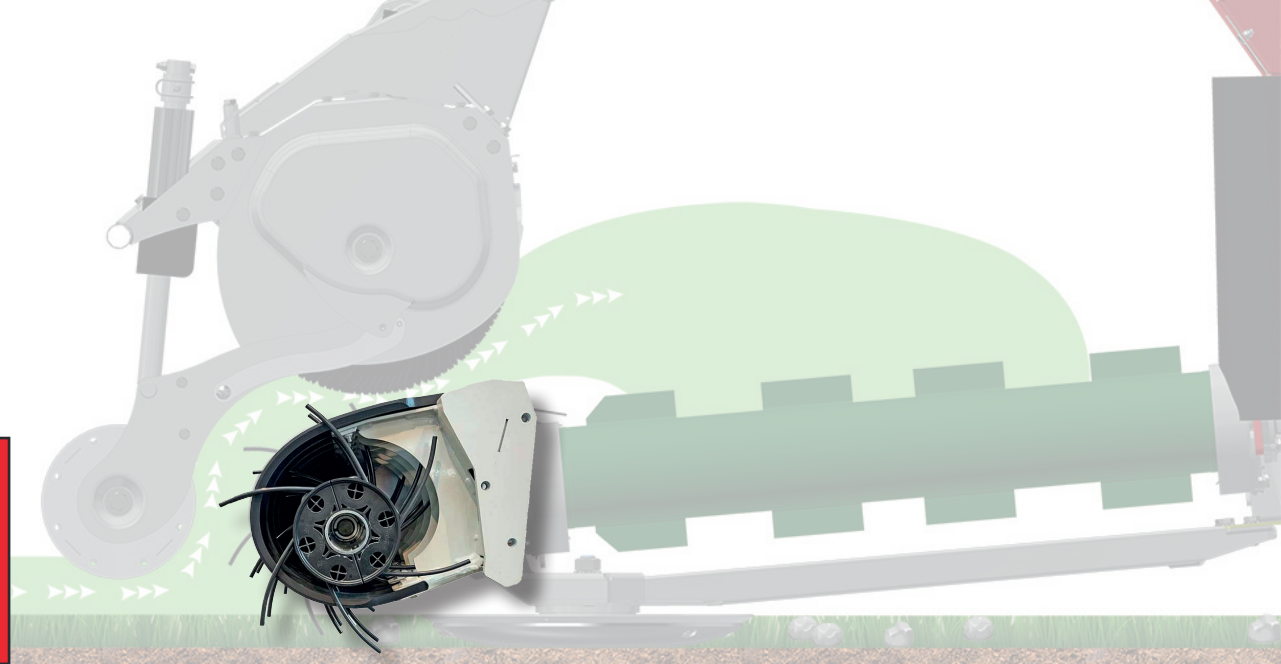

No aggressive ground contact possible

Due to the trailing geometry, aggressive contact with the ground contact is not possible at all. For short bumps, etc., additional ground adaptation can be achieved. This protects the whole system.

Stones and foreign bodies remain in place

Contact with stones and foreign bodies is repellent. As a result, they remain on the field. There are no stone splinters in the forage. The following harvester is protected.



Tine legs do not bend when cornering

RESPIRO Pick-Up technology has virtually no bent tines. The dragging geometry is the reason for this. A thankful advantage in practice. Tedious tine alignment is a thing of the past.

Plant stems are not uprooted

This is particularly important with maize straw. Stalks cannot be uprooted, so neither stones nor soil get into the straw. Ideal for minimising wear on subsequent cutterbars.

Less wear and breakage

Due to the low load on the tine legs there is significantly less wear. The tines are protected and have a very long service life.

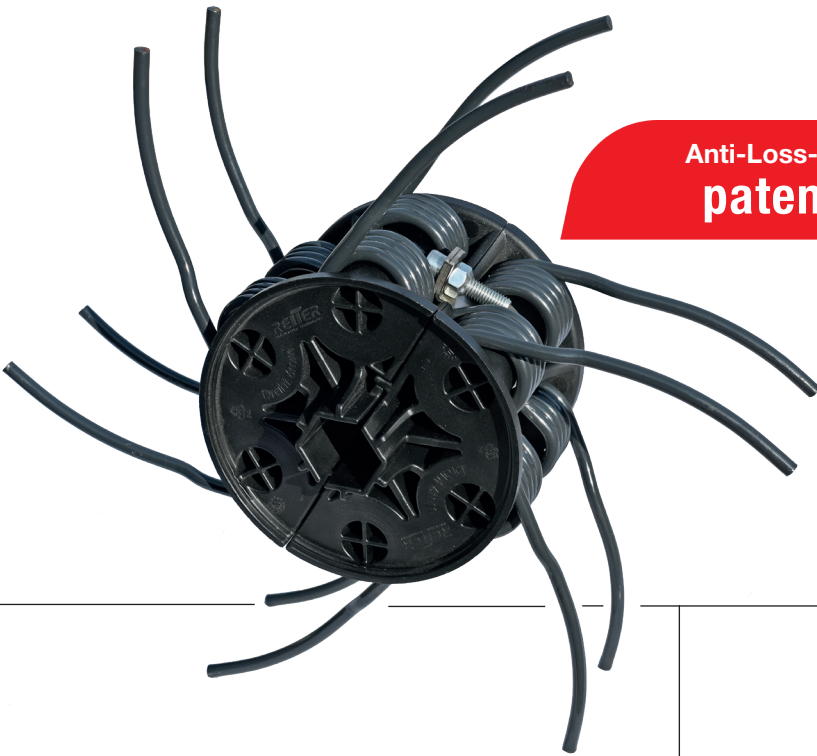

**Anti-Loss-System
patented**

Simple & safe

Anti-Loss system

The dream of every technician : to have to screw as little as possible to the pick-up.
The Anti-Loss System fulfils this dream and makes it possible.



The technology

Unique tine mounting

A single M8 bolt secures 6 double tines.
Changing the tines is simple and quick.

Tines broken in the winding are not lost

In the event of a broken coil, the tine remains suspended in the support. Thus, broken tines run in circles without consequential damage - replacement at the next opportunity is sufficient.

Image: Slurry particles, stones and dirt remain on the ground

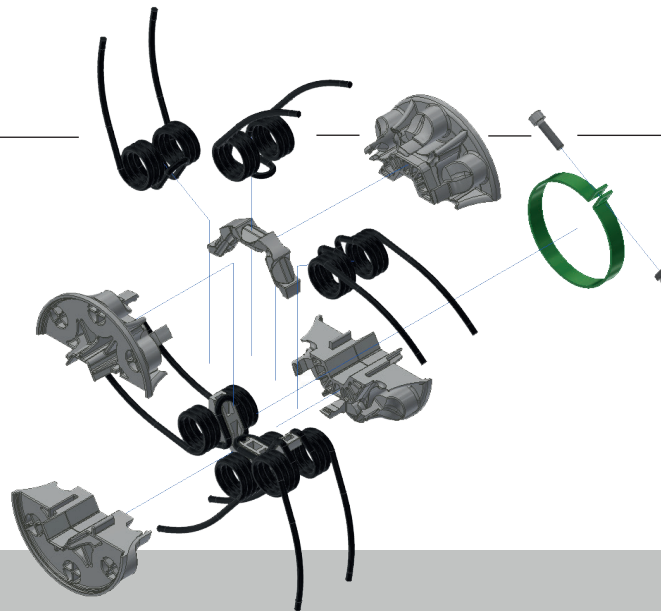

Tine winding is supported from the inside

Another feature of the ingeniously simple solution: the tine winding is solidly supported from the inside. This guarantees an extremely long service life of the tines.

Convincing Simple

The camless pick-up

A belt rake has many metres of pick-up.
 With conventional systems, a large working width means that several cam tracks have to be installed.
 That is not the future of the belt rake.
 A new concept is needed. Easy maintenance demands a camless system.
 The **RESPIRO** technology is the first belt rake with a camless pick-up, a real milestone.

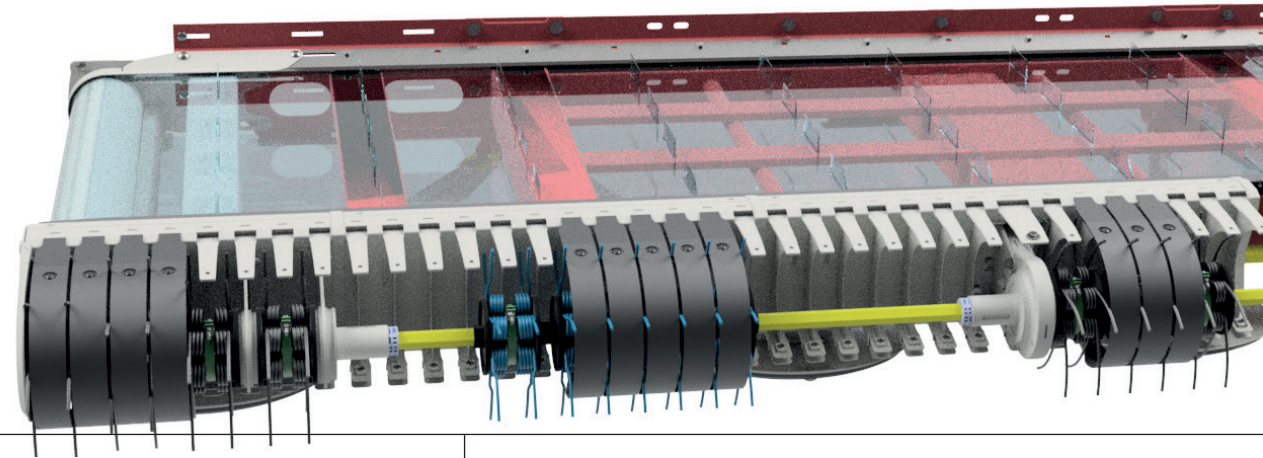

maintenance-free!

Radically simply built

Simple rotation, no additional moving parts, no additional wear and tear. Compact, robust, reliable, simple. Built for practice.

Significantly fewer components

A central axle with a hexagonal profile transmits the power to the tine carrier discs. No unnecessary bearing points, control rollers, cam tracks and tine carrier profiles. Why complicate things when they can be so simple?

Centre drive with 2 double bearing units on each side

The torque of the pick-up shaft is halved. The centre drive with gears is maintenance-free.

No axial movement

Another significant technical plus point.
 The precise mounting of the pick-up tines combined with the axially backlash-free design of the fully loaded pick-up shaft reduces lateral wear between the pick-up tines and the scraper.
 A well thought-out overall system.

Allows small diameter

Little crop spread over the area - that is the highest challenge for a pick-up system.

Only the small diameter opens the door for an uncontrolled, simple pick-up.

Tine impact speed

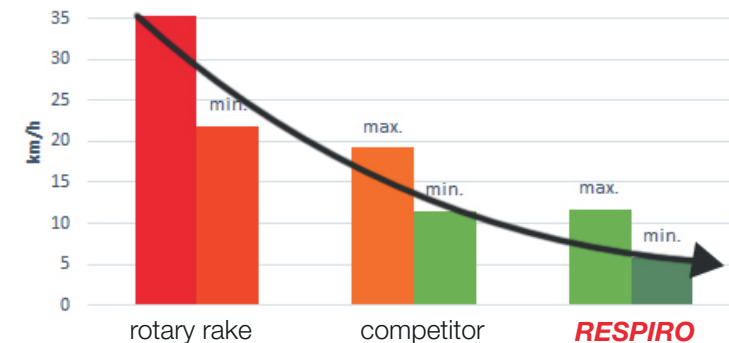

Gentle & powerful

Small diameter

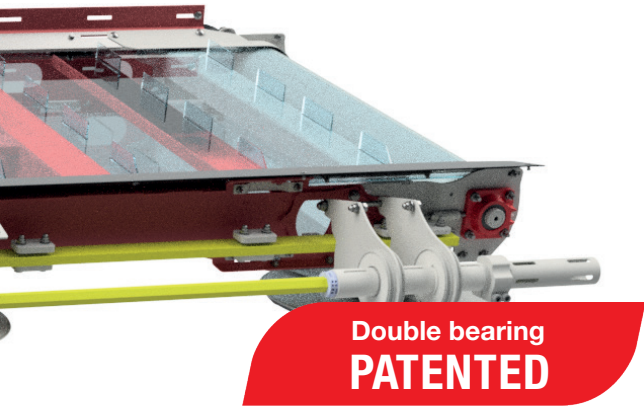

The small diameter, or to put it another way, the low height of the pick-up is another key of the **RESPIRO** technology. The flow of the crop is ideal. The crop flows harmoniously onto the conveyor belt. Convincingly simple and efficient. The performance of the system is amazing. Depending on the operating conditions, working speeds of up to 25 km/h are possible. Despite the high performance, the mechanical stress on the crop remains low. This ensures high protein content through very low crumble losses of valuable leaf mass.

Small distance between tine rows

The six-row pick-up with such a small diameter delivers a harmonious sequence of tines. The seamless sequence of tines lifts the crop quickly and very gently from the ground. Optimum crop flow is the result.

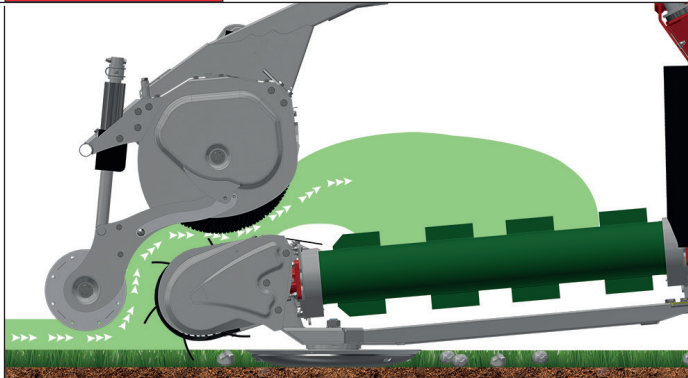

Powerful even with short forage

The small pick-up lifts the forage out of the stubble immediately and without interruption. This means that even short forage can be raked effectively. This increases the productivity of the **RESPIRO** belt rake enormously.

Low tine impact speed

Due to the small overall height of the Pick-Up, the tine speed can be kept very low. The crop wave nevertheless floats up, is taken over by the rotor and guided onto the conveyor belt. Especially for legumes and for crops with a high dry matter content. Less leaf loss and more protein.

Enables the trailing tine

The trailing tine was never “planned”. Practice has produced it. Because the diameter of the pick-up is so small, the tines can be dragged. At the height of the mowing horizon, the tines lift the crop dynamically out of the stubble. The secret of the **RESPIRO** system.

Underruns large swath

When turning swaths and with high harvest yields, the small pick-up has another decisive advantage: the harvest mass floats on the pick-up. Harmonious, powerful and efficient. Despite very high masses, the Pick-Up requires very little drive torque. Ideal for energy efficiency and service life.

Perfect crop flow

Conveyor rotor and swath roller

A guided crop flow delivers very high flexibility in operation. Whether the crop is short or long, dry or wet, the working speed high or low, the feed rotor ensures a good flow. This delivers uniform swaths. The key to the productivity of the following harvester.

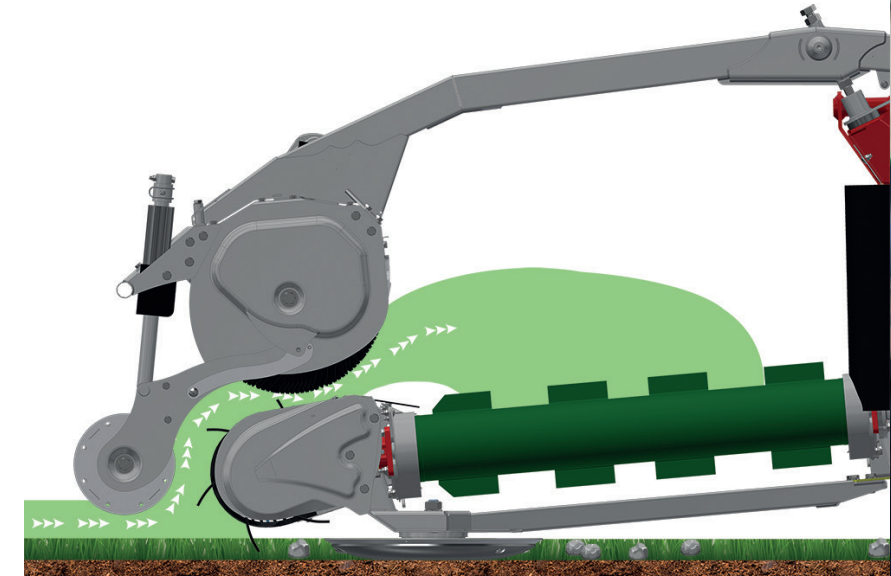

Ensures a uniform crop flow

The synchronously running elements pick-up and conveyor rotor work hand in hand. The pick-up lifts gently from the ground, the rotor conveys onto the belt. An ideal combination.

The conveyor rotor is one of the decisive factors for the high working speed.

Conveyor rotor hydraulically relieved and height adjustable.

If a lot of mass comes in or a swath is moved again, the rotor automatically moves upwards, thus increasing the swallowing capacity and the performance.

Swath roller guides the crop flow to Pick-Up

The swath roller allows even very short crops to be picked up from the ground with little loss. Even at the headland, no forage remains in front of the pick-up when it is lifted.

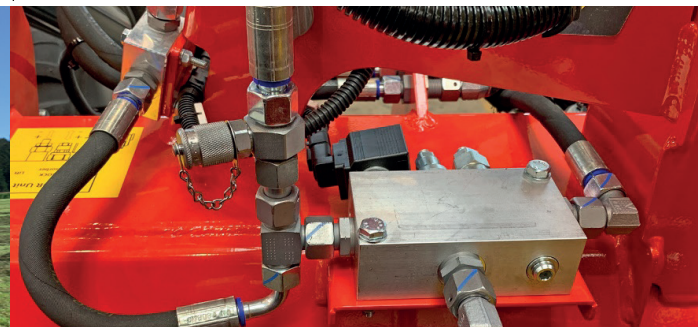

Rotor module: Suspension and damping from the rotor can be adjusted.

Conveyor belt

Belt with split studs

Better conveying effect especially with dry material (hay, straw, lucerne) More even conveying, no pile formation

Multi-layer PVC belt with edge reinforcement

- ▶ Longer service life
- ▶ Better lateral stability



The technology



Belt drive is via hydraulic motor OMR with leakage oil line - a coupling for tension-free drive sits in between.

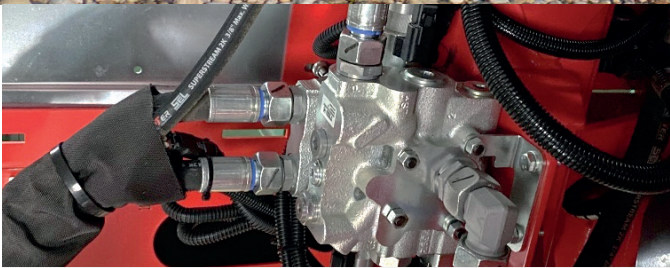

The belt valve determines the depositing direction and the belt speed - both adjustable via the terminal.

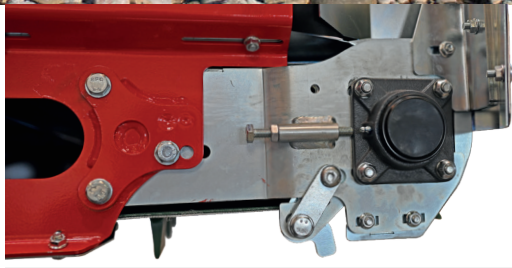

Belt roller bearing via robust standard flange bearings - adjustable scrapers clean the rollers.

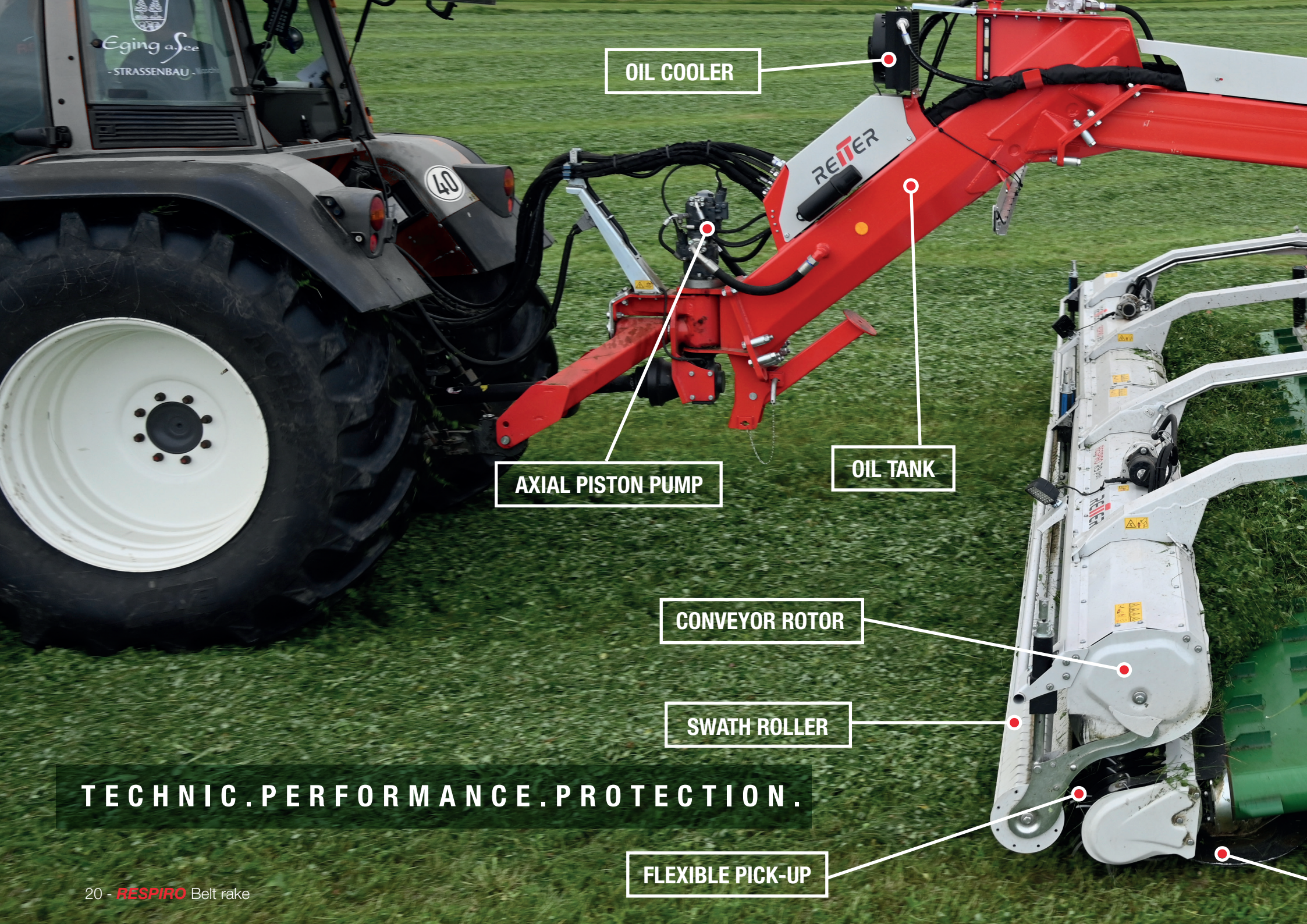

OIL COOLER

AXIAL PISTON PUMP

OIL TANK

CONVEYOR ROTOR

SWATH ROLLER

FLEXIBLE PICK-UP

TECHNIC. PERFORMANCE. PROTECTION.

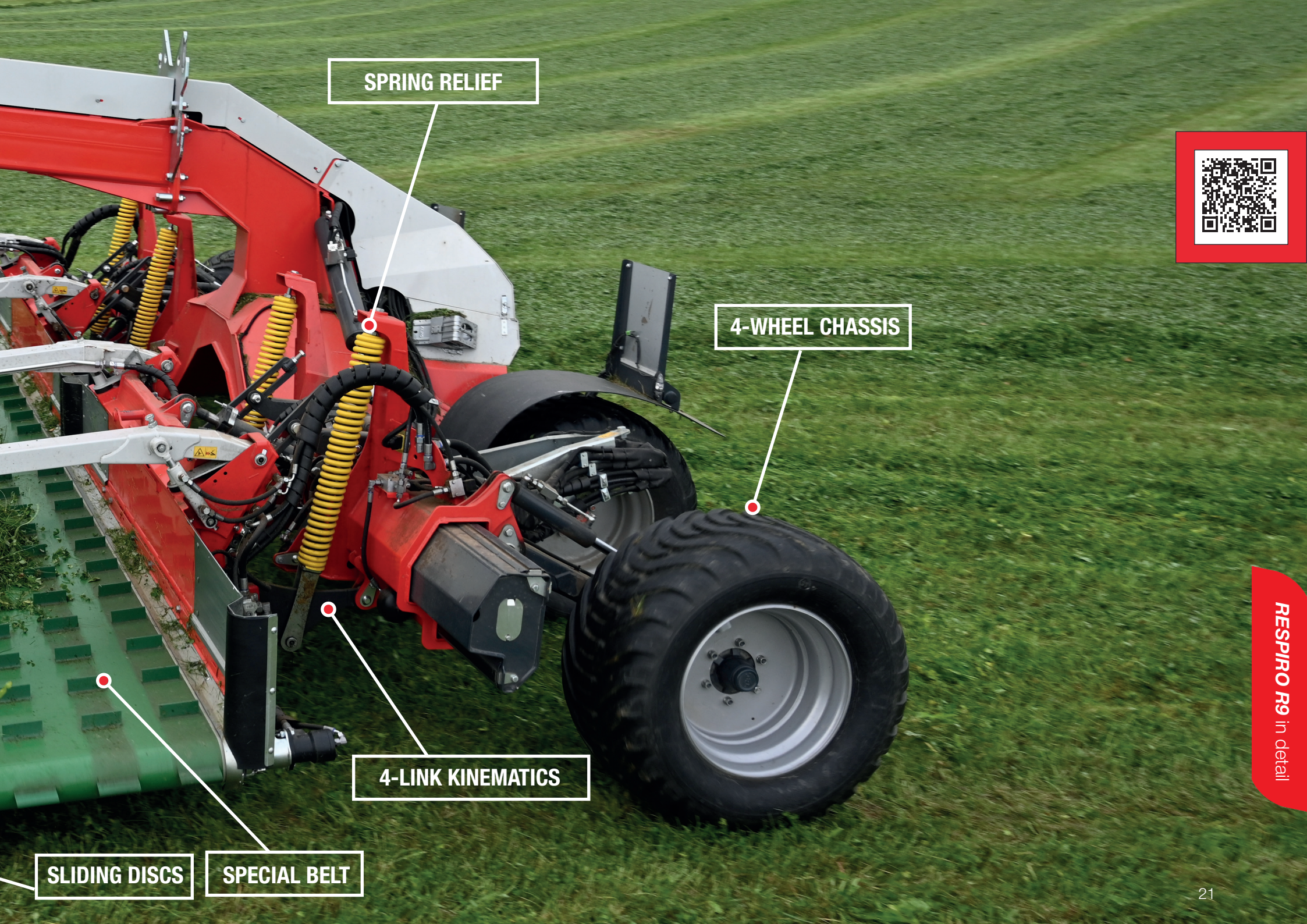

SPRING RELIEF

4-WHEEL CHASSIS

4-LINK KINEMATICS

SLIDING DISCS

SPECIAL BELT



RESPIRO R9 in detail

RESPIRO R9 profi - master of flexibility

Possibilities for swath placement

The **RESPIRO** R9 profi is our multitalent.

Thanks to the various placement options, it always delivers the right swath mass for the subsequent harvesting technique. No matter whether wet permanent grassland, dry lucerne or massive straw stands. The RESPIRO R9 profi masters everything, the operating conditions are almost unlimited.



Centre swath

- ▶ 8-9 m working width
- ▶ 1-2 m swath width - easy adjustment to the following implements.
- ▶ Perfectly formed, even swath - higher driving speed and utilisation of the harvester.
- ▶ Straw swath from 7 m combine cutterbars swathed together without loss.



Side swath

- ▶ Double side swath 15 m in one swath - more mass than a 4-rotor rake can manage.
- ▶ Multiple lifting with less forage volume to over 50 m - no increase in forage contamination.
- ▶ Sufficient swath mass for harvesting equipment can be achieved - fewer passes of the harvesting chain - higher efficiency - lower diesel consumption - less soil compaction.



2 single swath

- ▶ Best suited for hay to put down individual night swaths or to make two individual swaths if there is a lot of mass.
- ▶ Turn 2 straw or alfalfa windrows in one pass - better aeration - better drying.



Half side swath

- ▶ For extremely high swath masses.
- ▶ For 15 m centre swath - works perfectly with tracking system.

Top productivity of your harvesting technology

Perfect swaths from the first to the last cut

Driving strategies

With the most varied driving strategies, sufficient mass is efficiently achieved for the harvesting chain. Thanks to the small pick-up diameter and the conveyor rotor, multiple lifting is no problem. The swaths are laid down loosely. Better post-drying, higher travel speed of the harvester. In comparison, the rotary rake compacts the crop: poorer post-drying.

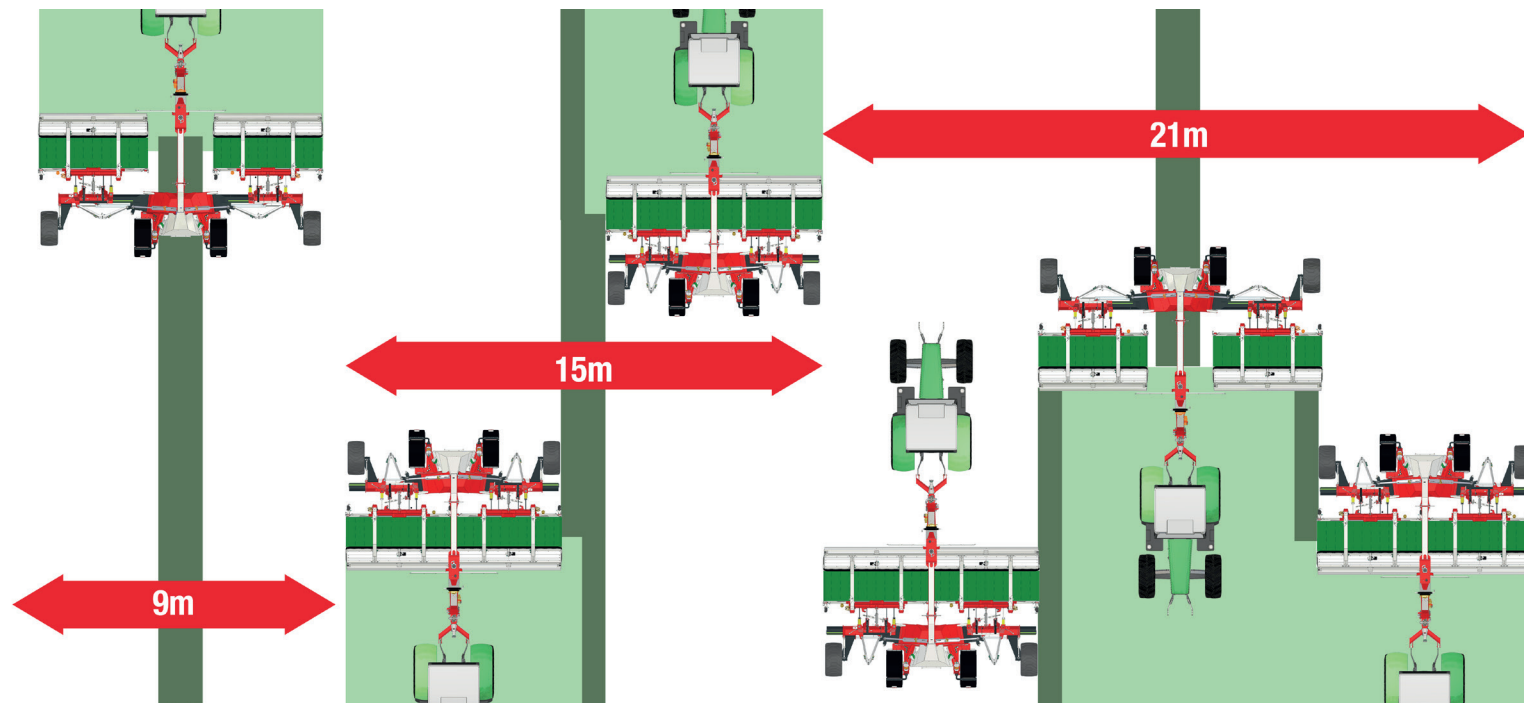

RESPIRO R9 in detail



Built for hard continuous use

Robust & manoeuvrable

For high performance it is necessary not to lose time at the headland.

Attached to the pendular lower link axle cat. 2, you can achieve a steering angle of up to 94°. This extremely high manoeuvrability allows you to drive the headland in one go. Great.

Due to the pivot point being far behind the lower link axle, the machine also has very good tracking characteristics, especially in field corners.

The pump for the hydraulic drive is located directly above the pivot point of the attachment and is driven by the gearbox below. This swivels with every steering movement over the headstock. This means that the PTO shaft always runs straight and has a long service life.

As the pump sits above the pivot point, there is no relative movement between the pump and the tank, so the suction and pressure lines do not move. This increases the service life of the hoses and ensures operational safety.

The foldable support foot sits under the main frame and enables easy attachment or maintenance of the headstock and PTO shaft.



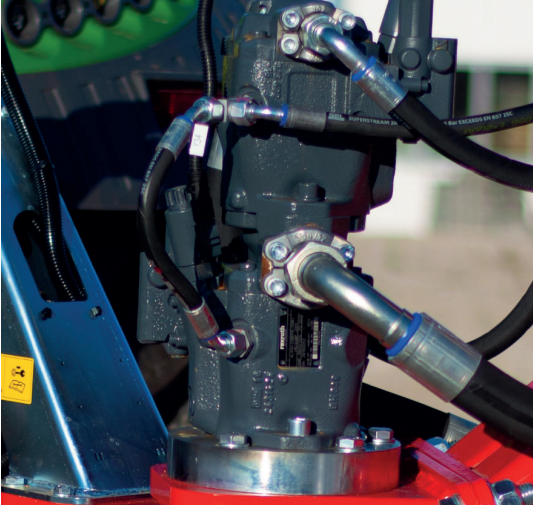

**RELIABLE
WITH
RESPIRO.**

Powerful & durable

Hydraulic pick-up, rotor and belt drive via on-board hydraulics

The heart of the hydraulic drive is the double axial piston pump from Bosch Rexroth. The big advantage over a conventional gear pump is that the flow rate can be adjusted at the terminal independently of the PTO speed.

- ▶ Perfect adaptation to every harvest situation
- ▶ Tractor operates in the best working range (torque, consumption)
- ▶ Best efficiency
- ▶ Lowest oil heating
- ▶ Recommended PTO speed at approx. 700 - 800 rpm.

Stay cool.

The oil tank is integrated in the front part of the main frame, 200 litres of oil are on board and ensure good heat dissipation. The additional oil cooler runs permanently, ensuring safe operation even on the hottest days.

- ▶ System temperature remains low
- ▶ Long service life of the hydraulic components
- ▶ Integrated reversing circuit at the oil cooler for automatic cleaning.

Compact & safe in road transport

Easy folding & safe road transport

Folding and unfolding the machine is done at the touch of a button.

- ▶ Safe transport locking of the working units via double hooks.
 - No rocking even at high transport speeds.

Compact transport dimensions.

- ▶ Transport width: 2.96 m at the wheels
- ▶ Machine width: 2.60 m - best visibility backwards
- ▶ Transport height: 3.95 m
- ▶ Mudguards
- ▶ Warning signs with marker lights.

The **RESPIRO R9 profi** is equipped with an air brake as standard. The Tristop brake cylinder is also the parking brake.



RESPIRO R9 in detail



Unbeatable driving experience and maximum safety

Unique: 4-wheel chassis

The combination of smooth running and ground hugging is the basic prerequisite for accurate and fast work. With the 4-wheel chassis, Reiter solves this in a way that is unique on the market.

In working position, the lateral chassis outriggers are in floating position, guided over the outer wheels they adapt perfectly to any ground unevenness and guide the working unit even at high working speeds.

The 4-wheel chassis in turn ensures that the machine does not rock on the headland or during individual lifting of the working units.

Even on slopes, the belt rake follows the track without tipping or slipping (approx. 2200 kg drawbar load).

Due to the even weight distribution (approx. 1100 kg/wheel) on all 4 large-dimensioned wheels (550/45-22.5), the RESPIRO is also ideally suited for wet conditions (boggy soils) despite its higher weight. Furthermore, the 4-wheel chassis reduces the forces on the main frame.

This results in a much longer service life. Designed for the toughest operating conditions.

All these points are a huge advantage over the conventional system with 2-wheel chassis. Robust construction from the attachment to the undercarriage.





THE FORAGE CLEAN AS NEVER BEEN.

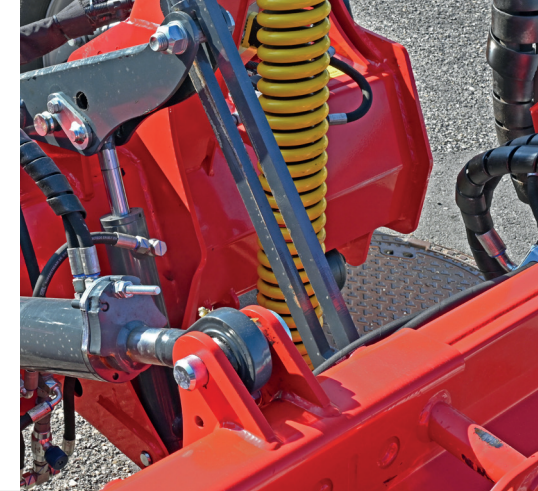

Quick turn

Lifting on headland

A real 3-point linkage is mounted on the lateral chassis boom.

- ▶ Best guidance of the working unit over uneven ground.
- ▶ Always parallel lifting and lowering to the ground, quick entry and exit at the headland without delays.
- ▶ Due to the large lifting height at the headland, even finished swaths are easily driven over.
- ▶ Single lift for swathing out pointed areas.

Wear reduction

Flying suspension in straw operation due to lowering limitation

No constant ground contact, less dust generation, less wear on the sliding discs (low heating, no flying sparks) less tine wear, less diesel consumption. The working unit is carried just above the ground surface by the 4-wheel chassis. Simplest adjustment of the raking height via the drawbar.



RESPIRO R9 in detail

Responsive - Consistent raking height

4-link kinematics

Clean forage pick-up and low forage contamination are the primary objectives in forage harvesting.

On the *RESPIRO* R9 profi , the unique 4-link kinematic, in addition to the flexible pick-up and 4-wheel chassis, ensures perfect guidance of the work units, unbeatable, rapid ground hugging.

- ▶ 4-link kinematics
- ▶ Two lower links rising to the front and a hydraulic upper link guide the working unit.

The point of intersection (instantaneous pole=MP) of the extension lines of the lower link and upper link is below the ground. This results in easy upward deflection of the working units.

In operation, the working unit becomes lighter - less wear on the skid plates and turf protection.

- ▶ Enables higher driving speed
- ▶ High durability

Every height adjustment leads to a slope adjustment

- ▶ Consistent raking height
- ▶ Less potential ground contact
- ▶ Less forage contamination
- ▶ Less raking losses

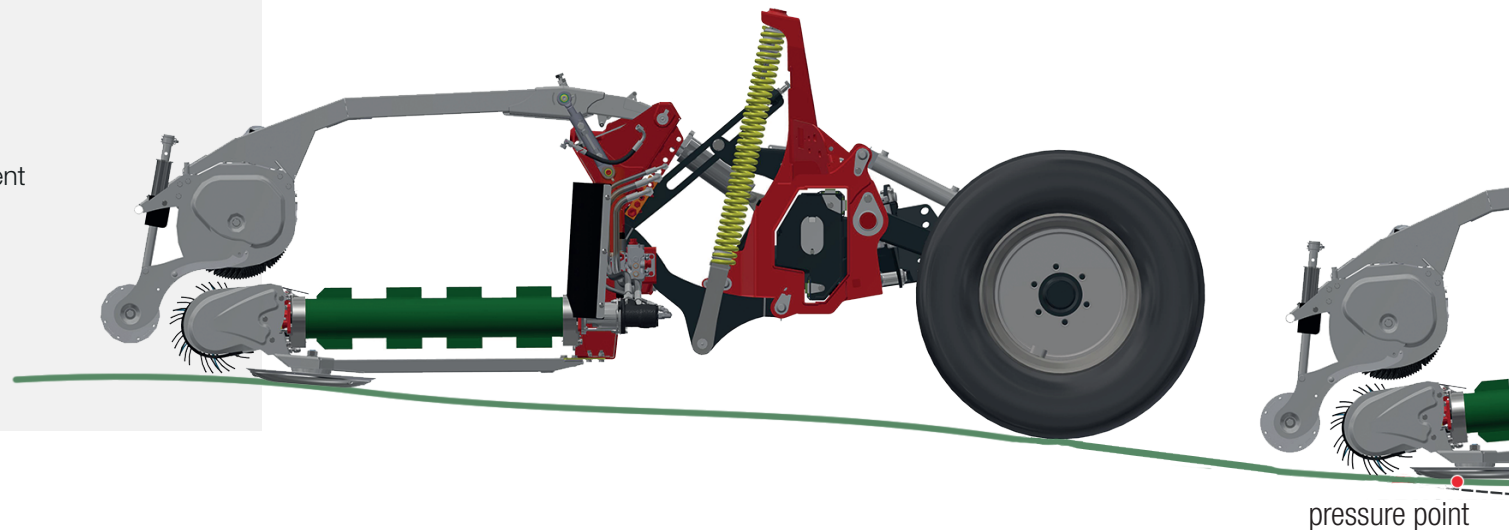



Rake height adjustment via top link.
The basic raking height is set via spacer plates.
At the push of a button in the terminal, it is possible to work lower at the headland, for example.

GLIDING CONFIDENTLY OVER THE FIELD.



Linkages with greasable ball eyes.
Durable construction.



Simple and effective Proven spring relief

Effective spring relief of the working units ensures low contact pressure. Low wear on the wear plates, the turf is not damaged, no grinding marks.

- ▶ An important component to cleanest forage
- ▶ System reacts very quickly - working speeds up to 25 km/h possible
- ▶ Boomerang link for uniform relief over the entire working distance +/- 300 mm
- ▶ Approx. 200-300 kg ground pressure
- ▶ Robust and reliable.”

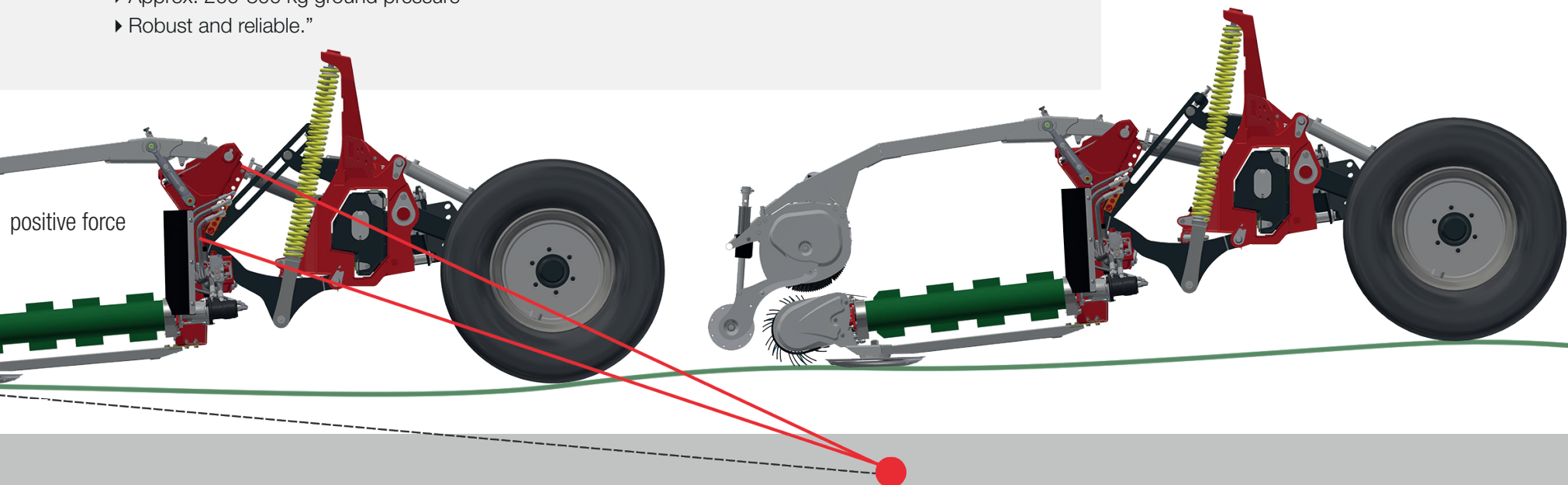

RESPIRO R9 in detail

Smart operation

Simple & practical



The pick-up, rotor and belt are driven by their own on-board hydraulics. A PTO speed of 700 - 800 rpm is recommended here, so that the tractor runs in the optimum speed range, efficiently and fuel-saving. 2 double-acting control units from the tractor are used for lifting the left and right working units. Comfortable lifting via operation in the armrest or from the joystick, without constant reaching over to the terminal. It is ideal if the lifting times (flow times) can be stored. Folding, working width adjustment and rotor height are operated via the terminal. A load-sensing connection or a single-acting connection with return is required for this.

Terminal functions

- ▶ Folding into transport or working position at the push of a button.
- ▶ Deposit mode (centre / side) - Working width adjustment incl. 2 memories
- ▶ Deposit direction (centre deposit / 2 single swaths left right; side deposit left or right / half side swath)
- ▶ Adjustment of pick-up speed with rotor / belt speed
- ▶ Automatic belt stop at headland - clean headland, swath is not pulled out with it.
- ▶ Belt stop - so that corners, for example, can be neatly cleared
- ▶ Automatic speed control - 2 modes - PU speed and belt speed depending on forward speed and PTO speed
- ▶ Automatic delivery left / right
- ▶ Rotor lift (hay, straw,...)
- ▶ Adjustment of raking height via hydraulic top link
- ▶ Night mode (incl. key lighting)
- ▶ 2x LED working lights on/off
- ▶ Hour and hectare counter
- ▶ Display of working width, working mode, depositing direction, forward speed, belt speed, pick-up speed.



RESPIRO THE FUTURE.

Optional

The right equipment for your needs

- ▶ Sliding plate Robalon
- ▶ Swath curtain
- ▶ Air brake or hydraulic brake (country-specific)

Data sheet RESPIRO R9 profi

Working width centre swath [m]	7.50 - 9.00
Swath width [m]	0.50 - 2.00
Working width side swath [m]	7.00 + Swath
Conveyor belt width [mm]	1000
Transport length [m]	6.70
Transport width [m]	2.96
Transport height [m]	3.95
Weight [kg]	6400
Tyres	550/45-22.5
Area output [ha/h]	4 – 10
PTO shaft [rpm]	1000
Required hydraulic connections	2 DA + load sensing
Required electrical connections	ISOBUS, 7-pin plug
Brake	Air brakes

Requirement for the tractor

Required connections

- ▶ 2x DA for lifting the left and right working unit
- ▶ Loadsensing for comfort operation - also possible without LS (pressure circulation)
- ▶ PTO shaft 1 3/8 6-splined 1000 rpm
- ▶ Power supply via Iso-Bus socket (63 A)
- ▶ 7-pin plug for indicators and lighting
- ▶ 2-wire air brake / hydraulic brake
- ▶ Min. 130 hp on level ground, 6 cylinder tractor or front ballast an advantage.



RESPIRO R9 in detail

COWS WOULD BUY **RESPIRO**.



REITER
www.reiter-respiro.com

RT Engineering GmbH
Eben 5a, 4716 Hofkirchen a.d.T.
Austria

Tel.: +43 7248 66717
E-Mail: office@rt-e.at
www.reiter-respiro.com



@RT.Engineering.GmbH



@reiter_respiro_official



ReiterInnovativeTechnology

RESPIRO - Pastures, animals, machines and men respire